

IOT Prison Break Monitoring & Alerting System

Abstract

Prison escapes pose a serious threat to public safety, and traditional surveillance methods are often insufficient to prevent them. The IOT Prison Break Monitoring & Alerting System offers a smart solution by integrating Internet of Things (IoT) technology with real-time prisoner tracking. Each prisoner is equipped with an RF tracker that transmits a unique code. A central Atmega microcontroller-based system continuously scans these RF signals. If a prisoner crosses the security boundary and the signal is lost, the system instantly identifies the missing individual and alerts authorities via an online IOTGecko portal. The alert includes prisoner details and triggers sound alarms to initiate immediate response.

Aim

To design and implement an IoT-based real-time prisoner tracking and alert system using RF technology to prevent prison escapes and ensure public safety.

Objectives

- To assign each prisoner a unique RF transmitter for identity tracking.
- To monitor the real-time presence of all inmates within prison boundaries.
- To detect escape attempts when RF signals go out of range.
- To alert authorities instantly through an IoT-based web portal.
- To sound a local alarm for immediate response within the premises.

Working Principle

Each inmate is tagged with an RF transmitter broadcasting a unique ID. Central monitoring units equipped with RF receivers continuously scan for these signals. The Atmega microcontroller processes the data and checks for signal loss. If a prisoner's signal is not detected, the microcontroller triggers a buzzer and sends data to the online alert portal (IOTGecko). Authorities receive the alert with the prisoner's identity, allowing them to act before the prisoner escapes far through internet.

Block Diagram:

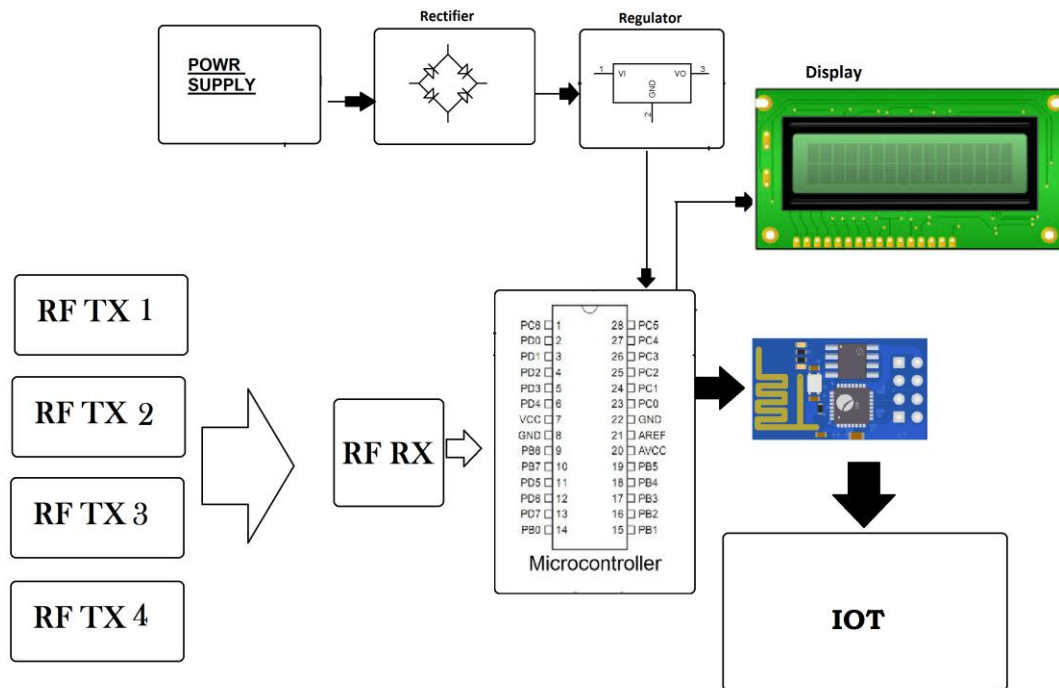

Hardware Components

- Atmega Microcontroller
- RF Transmitter and Receiver
- Wi-Fi Module
- Crystal Oscillator
- Buzzer
- LED
- Switches and Push Buttons
- Diodes, Transistors, Resistors, Capacitors
- Transformer/Adapter
- Cables, Connectors, PCB/Breadboard
- ICs and IC Sockets

Software Components

- Arduino IDE / Compiler
- Embedded C Programming
- IOTGecko (for alert and monitoring portal)

Advantages

- Real-time prisoner tracking
- Early detection of prison escapes
- Remote alert system via internet
- Low-cost and scalable solution
- Easy integration with prison security systems

Disadvantages

- RF signal may face interference
- Limited range for RF communication
- Dependent on continuous internet connectivity
- Tracker may be removed or damaged

Applications

- Central and state government prisons
- Juvenile detention centers
- High-security military jails
- Psychiatric secure wards
- Immigration detention centers

Future Scope

- Integration with GPS for tracking escaped inmates
- Face recognition for enhanced verification
- AI-based movement pattern analysis
- Battery-powered tamper-proof wearable tags
- 24/7 monitoring dashboard with camera feed integration

Conclusion

The IoT Prison Break Monitoring & Alerting System is a proactive and smart approach to enhance prison security. By leveraging RF technology and IoT integration, the system ensures real-time monitoring and quick alerts during escape attempts. This system not only improves inmate tracking but also enhances public safety by enabling rapid action during critical situations.

AIMERS